

# EM100 load-cell electronics module

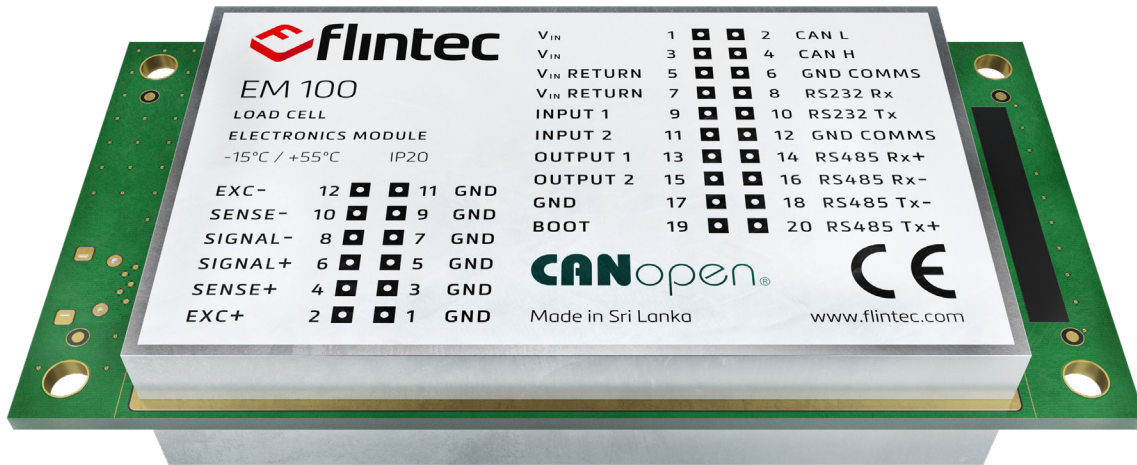

## product description

The EM100 is a high-precision amplifier that features an integrated analogue-to-digital converter. It leverages a 24-bit sigma-delta signal modulation to ensure exceptional resolution with low noise. Sporting an extensive selection of weighing and calibration functions, it suits a wide range of both static and dynamic weighing applications.

The device comes in four versions tailored to different applications, each certified to the relevant OIML legal-for-trade standards. An optional adapter board is available for simplified mounting to peripherals.

The device features a CAN interface with support for the CANopen protocol as well as full-duplex RS-232 and RS-485 interfaces. A USB interface is included for convenient configuration, setup and firmware upgrade. Communication to the module is based on ASCII characters sent to a variety of serial interfaces making it easy to connect to a PC, PLC or other devices. Setup is simple, using a terminal emulation program or FDC application software (available at flintec.com).

## available models

EM100-G	EM100-C	EM100-F	EM100-A
General purpose	Check-weighing	Gravimetric filling	Accurate weighing
DC	DC	DC	AC
OIML R76	OIML R51	OIML R61	OIML R76

## key features

High accuracy

Up to 1200 samples per second for DC models; 80sps for AC model

Extensive command set

Excitation for up to 6 load cells

CAN Interface with CANOpen Protocol.

Serial interface for direct connection to PC or PLC

GPIOs (2x logical inputs & 2x logical outputs)

6-wire technology

OIML 'legal-for-trade' certification

Uses Flintec FDC software (for analysis and config)

Optional adapter board



RoHS compliant



**flintec**  
quality + precision

## specifications

Model	EM100-G	EM100-C	EM100-F	EM100-A
Function	General purpose	Check-weighing	Gravimetric filling	Accurate weighing
Application modes	NAWI	AWI	AWI	NAWI
Bridge excitation	+5V <sub>DC</sub>			+5V <sub>AC</sub>
Sensor configuration	4-Wire or 6-Wire			
Accuracy class	III	XIII or XIII or Y(a) or Y(b)	Class III – Ref Class X(0.2); X(0.5); X(1); X(2)	II
Verification scale intervals	10,000			20,000
Minimum input sensitivity	0.05µV/d			0.02µV/d
Certified accuracy	0.3µV/vsi			0.1µV/vsi
Weighing range	Single Interval, Multi-Range or Multi-Interval			
	10,000/n x 10,000 (n = 1, 2, 3)			20,000/n x 20,000 (n = 1, 2, 3)
Resolution (external)	±350,000			±1,000,000
Analogue input range	±15mV (±3mV/V @ +5V <sub>DC</sub> Excitation)			±15mV (±3mV/V @ +5V <sub>AC</sub> Excitation)
Minimum load-cell impedance	58.3Ω (e.g. 1x350Ω; 4x350Ω; 6x350Ω; 4x1,100Ω)			
Maximum load-cell impedance	1,100Ω			
Linearity	±0.0005%			
Measurement sampling rate	75 to 1,200sps			2.5sps to 80sps
Calibration	Electronic Calibration in mV/V (eCal) or Test Weight(s)			
Digital low-pass filter	FIR Filter 2.5Hz to 19.7Hz or IIR Filter 0.25Hz to 18Hz adjustable in 8 steps			
Weighing functions	Zero, Gross, Tare, Net, Filter etc.			

### Interface 1: CAN Bus

Protocol	CANOpen
Baud-rate	10k, 20k, 50k, 125k, 250k, 500k, 800k or 1,000kBits/s
Frame format	Half-Duplex (8-Data Bits; No Parity; 1-Stop Bit)

### Interface 2: RS-232

Protocol	ASCII Characters
Baud-rate	9.6k, 14.4k, 19.2k, 38.4k, 57.6k, 115.2k, 230.4k or 460.8kBits/s
Format	Full-Duplex (8-Data Bits; No Parity; 1-Stop Bit)

### Interface 3: RS-485

Protocol	ASCII Characters
Baud-rate	9.6k, 14.4k, 19.2k, 38.4k, 57.6k, 115.2k, 230.4k or 460.8kBits/s
Format	Full & Half Duplex

### Interface 4: USB

Protocol	USB CDC (Configuration & Setup Only)
Baud-rate	Auto-Detected.

### 2x Logical Inputs

Maximum input voltage	+30V <sub>DC</sub>
Threshold voltage (approx.)	+3V <sub>DC</sub>
Input impedance (approx.)	>10k $\Omega$

### 2x Logical Outputs

Maximum voltage	+30V <sub>DC</sub>
Maximum power	300mW
Output configuration	Open Drain

### General

Power supply	+9.6V <sub>DC</sub> to +32V <sub>DC</sub>
Operating temperature range	-15°C to +55°C
Storage temperature range	-30°C to +70°C
Weight	30g approx.
Protection rating	IP20

product dimensions (mm)

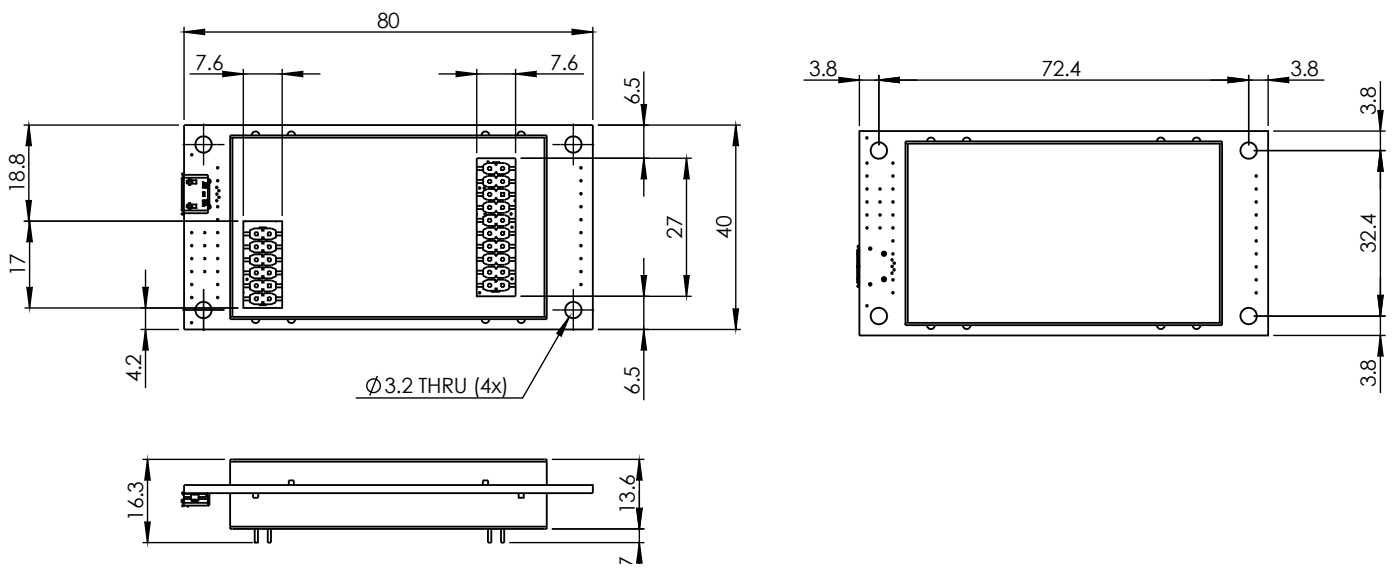

optional adapter board (mm)

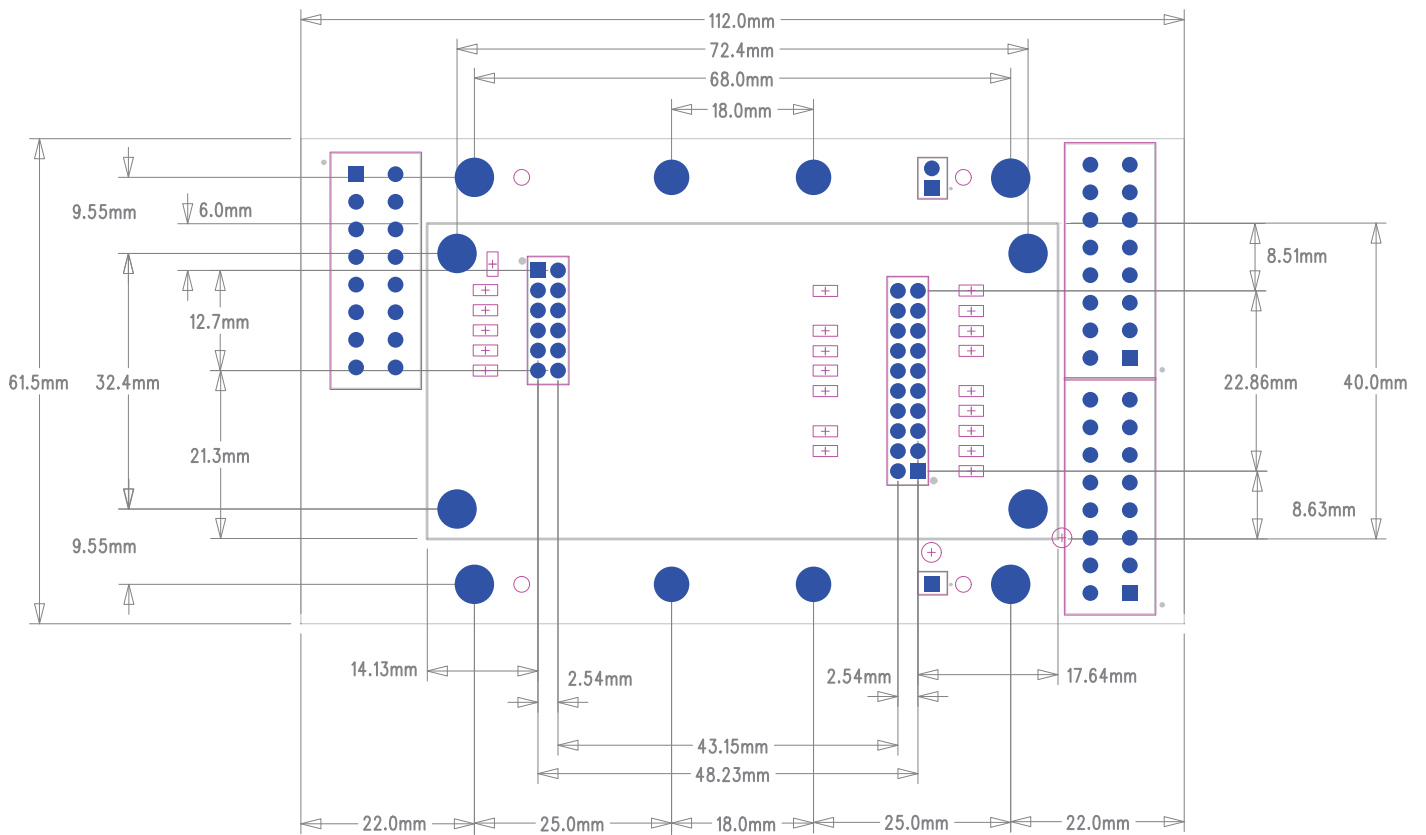

Dimensions and specifications are subject to change without notice.